

Racetrack

Featuring True Colors by Tula Pink

A beautiful maze of color swirls throughout this rainbow-inspired quilt, and the best part? It's all made from a single block, so rev up your half-square triangle skills.

Collection:	True Colors by Tula Pink
Technique:	Piecing
Skill Level:	Experienced Beginner
Crafting Time:	Longer term*
Finished Size:	80" x 80" (203.20cm x 203.20cm)

*Crafting time based on Experienced Beginner skill level

Featured quilt is a smaller version of the project; instructions are for a larger version.



COATS

Project designed by Linda and Carl Sullivan, Colourwerx

Tech edited by Linda Turner Griepentrog

Fabric Requirements

DESIGN	COLOR	ARTICLE CODE	YARDAGE
(A) Daisy Buds	Silver	PWTC029.SILVE	3½ yards (3.35m)
(B) Lady Bug	Mustard	PWTC027.MUSTA	⅓ yard (30.48cm)
(C) Lazy Stripe	Amber	PWTC028.AMBER	⅓ yard (30.48cm)
(D) Mini Owl	Bittersweet	PWTC026.BITTE	⅓ yard (30.48cm)
(E) Lady Bug	Nectarine	PWTC027.NECTA	⅓ yard (30.48cm)
(F) Daisy Buds	Fuchsia	PWTC029.FUCHS	⅓ yard (30.48cm)
(G) Making Waves	Sienna	PWTC030.SIENN	⅓ yard (30.48cm)
(H) Lady Bug	Lava	PWTC027.LAVAX	⅓ yard (30.48cm)
(I) Lazy Stripe	Candy	PWTC028.CANDY	⅓ yard (30.48cm)
(J) Mini Owl	Orchid	PWTC026.ORCHI	⅓ yard (30.48cm)
(K) Lady Bug	Abyss	PWTC027.ABYSS	⅓ yard (30.48cm)
(L) Daisy Buds	Wisteria	PWTC029.WISTE	⅓ yard (30.48cm)
(M) Making Waves	Navy	PWTC030.NAVYX	⅓ yard (30.48cm)
(N) Lazy Stripe	Sky	PWTC028.SKYXX	⅓ yard (30.48cm)
(O) Mini Owl	Pacific	PWTC026.PACIF	⅓ yard (30.48cm)
(P) Making Waves	Olive	PWTC030.OLIVE	⅓ yard (30.48cm)
(Q) Daisy Buds	Grass	PWTC029.GRASS	⅓ yard (30.48cm)
(R) Mini Owl	Mint Julep	PWTC026.MINTJ	⅓ yard (30.48cm)
(S) Making Waves	Ink	PWTC030.INKXX	¾ yard (68.58cm)

* includes binding

Backing (Purchased Separately)

44" (111.76cm)			7½ yards (7.01m)
OR			
108" (274.32cm)			
Freefall	Orchid	QBTP001.ORCHI	2½ yards (2.29m)

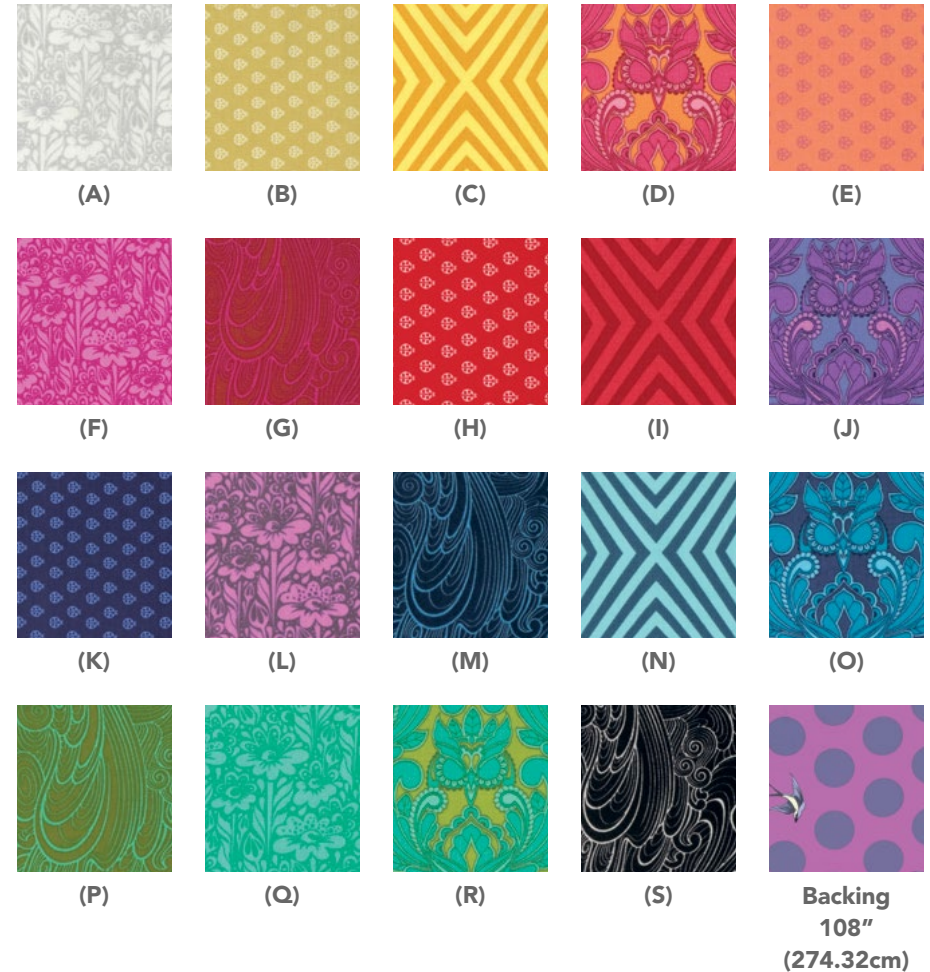

Backing
108"
(274.32cm)



COATS

Additional Requirements

- Coats Dual Duty XP® All-purpose Thread
- 88" x 88" (223.52cm x 223.52cm) batting
- Sewing machine
- Rotary cutter/mat/ruler
- Basic sewing and pressing supplies

Cutting

WOF = Width of Fabric

Fabric A, cut:

(26) 5" x WOF (12.70cm x WOF);
sub-cut (205) 5" (12.70cm) squares

Fabric B, cut:

(2) 5" x WOF (12.70cm x WOF);
sub-cut (10) 5" (12.70cm) squares

Fabric C, cut:

(2) 5" x WOF (12.70cm x WOF);
sub-cut (10) 5" (12.70cm) squares

Fabric D, cut:

(2) 5" x WOF (12.70cm x WOF);
sub-cut (12) 5" (12.70cm) squares

Fabric E, cut:

(2) 5" x WOF (12.70cm x WOF);
sub-cut (12) 5" (12.70cm) squares

Fabric F, cut:

(2) 5" x WOF (12.70cm x WOF);
sub-cut (12) 5" (12.70cm) squares

Fabric G, cut:

(2) 5" x WOF (12.70cm x WOF);
sub-cut (11) 5" (12.70cm) squares

Fabric H, cut:

(2) 5" x WOF (12.70cm x WOF);
sub-cut (10) 5" (12.70cm) squares

Fabric I, cut:

(2) 5" x WOF (12.70cm x WOF);
sub-cut (10) 5" (12.70cm) squares

Fabric J, cut:

(2) 5" x WOF (12.70cm x WOF);
sub-cut (11) 5" (12.70cm) squares

Fabric K, cut:

(2) 5" x WOF (12.70cm x WOF);
sub-cut (11) 5" (12.70cm) squares

Fabric L, cut:

(2) 5" x WOF (12.70cm x WOF);
sub-cut (11) 5" (12.70cm) squares

Fabric M, cut:

(2) 5" x WOF (12.70cm x WOF);
sub-cut (15) 5" (12.70cm) squares

Fabric N, cut:

(2) 5" x WOF (12.70cm x WOF);
sub-cut (14) 5" (12.70cm) squares

Fabric O, cut:

(2) 5" x WOF (12.70cm x WOF);
sub-cut (15) 5" (12.70cm) squares

Fabric P, cut:

(2) 5" x WOF (12.70cm x WOF);
sub-cut (13) 5" (12.70cm) squares

Fabric Q, cut:

(2) 5" x WOF (12.70cm x WOF);
sub-cut (13) 5" (12.70cm) squares

Fabric R, cut:

(2) 5" x WOF (12.70cm x WOF);
sub-cut (15) 5" (12.70cm) squares

Fabric S, cut:

(9) 2½" x WOF (6.35cm x WOF) strips, for binding

Sewing

All seam allowances are ¼" (.64 cm) and pieces are sewn right sides together.

1. Draw a diagonal line on the back of each 5" (12.70cm) **Fabric A** square (**Fig. 1**).

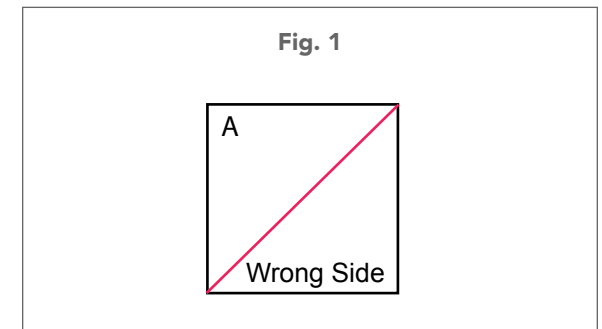

- Pair a marked **Fabric A** square with a 5" (12.70cm) colored square. Stitch $\frac{1}{4}$ " (.64cm) on both sides of the marked line (**Fig. 2**).

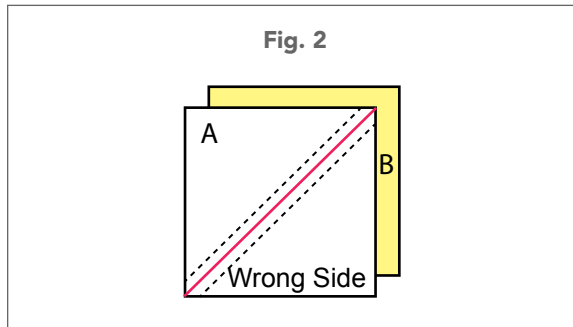

- Cut the squares apart directly on the marked line (**Fig. 3**) to make (2) half-square triangle (HST) units. Press the seams toward the darker fabric.

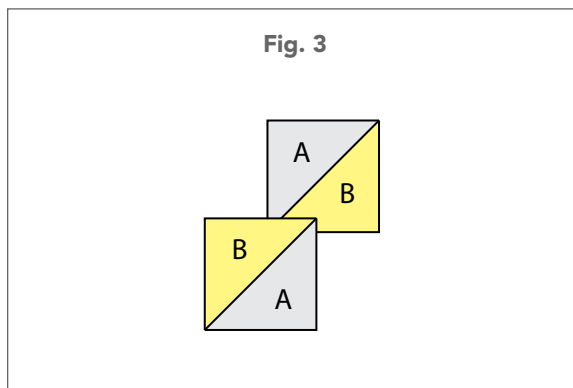

- Trim each HST unit to $4\frac{1}{2}$ " (11.43cm) square (**Fig. 4**).

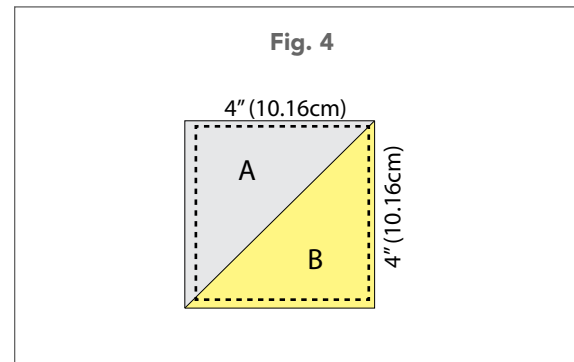

- Repeat Steps 1-4 with all the remaining 5" (12.70cm) squares making the fabric combinations and total units shown in **Figure 5** on page 5. (Note: You will have some extra pieces leftover to save for another project.)

Quilt Top Assembly

- Following the **Quilt Layout** diagram on page 6 for color placement and orientation, lay out the blocks in (20) rows of (20) blocks each.
- Sew the blocks together in each row and number the rows for easier assembly. Press the seams in alternate directions for adjacent rows.
- Sew the rows together in order, matching adjacent seams. Press the seams in one direction.

Finishing

- Sew together the (9) $2\frac{1}{2}$ " x WOF (6.35cm x WOF) **Fabric S** binding strips end to end using diagonal seams. Press the seams open. Press the binding strip in half wrong sides together.
- Layer the backing (wrong side up), batting, and quilt top (right side up). Baste the layers together and quilt as desired. Trim excess batting and backing even with the top after quilting is completed.
- Leaving an 8" (20.32cm) tail of binding, sew binding to top of quilt through all layers matching all raw edges. Miter corners. Stop approximately 12" (30.48cm) from where you started. Lay both loose ends of binding flat along quilt edge. Where these two loose ends meet, fold them back on themselves and press to form a crease. Using this crease as your stitching line, sew the two open ends of the binding together right sides together. Trim seam to $\frac{1}{4}$ " (.64cm) and press open. Finish sewing binding to quilt.
- Turn the binding to the back of quilt and hand-stitch in place.



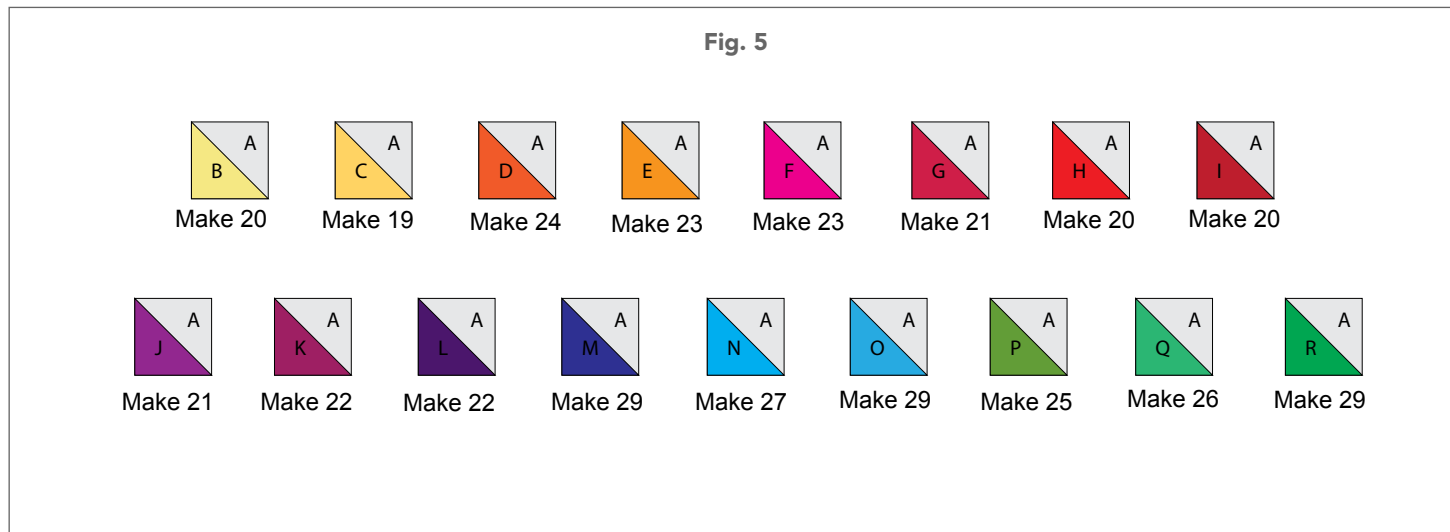

Quilt Layout

